

The stainless steel paddlewheel flow sensor type F111 offers high strength and mechanical resistance applied to insertion technology. The sensor can be assembled in pressurized pipes using a proper clamp saddle and it allows, by a simple procedure, to directly measure the internal diameter during the installation, enabling to precisely position the sensor into the pipe and get the max accuracy. It can measure flow from 0.15 m/s (0.5 ft/s) and is suitable for remote totalization when coupled with the Flow Monitors.

Main Features

- Adjustable sensor position.
- Stainless steel construction.
- Hot-Tap installation.
- Pressure intake.
- Standard 2" GAS (BSP) process connection.
- Battery powered version.
- Compatible with most Data Loggers.

Applications

- Water distribution.
- Leak Detection or Monitoring.
- Irrigation.
- Water treatment and regeneration.
- Ground Water Remediation.
- Filtration systems.

Technical Features

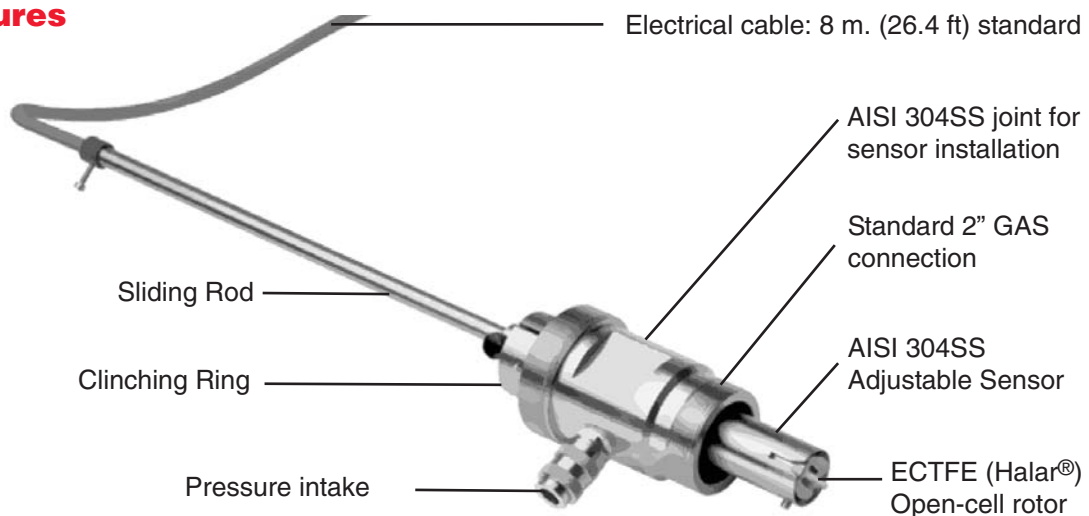

Halar® is a registered trademark of Ausimont-Solvay.

Operating principle

The flow sensor consists of a transducer and a five-blade open cell paddlewheel using insertion technology. The paddlewheel is equipped with a permanent magnet integrated into each blade. As the magnet passes close to the transducer a pulse is generated.

The liquid flowing in the pipe makes the paddlewheel rotating, producing a square wave output signal. The frequency is proportional to the flow velocity. The Hot-Tap sensor can be installed without system shutdown using any kind of Hot-Tap clamp saddles or clamp saddles with isolation valve.

Engineering Data

- The flow sensor is available with Hall effect transducer (standard) and Coil effect transducer (battery operated).
- The Hall sensor operates with a power supply from 5 to 24 VDC @ < 30 mA.
- The Coil sensor operates with a power supply from 3 to 5 VDC or 3.6 Volt Lithium battery and a current consumption < 10 μ A.
- The standard output is a square wave with a frequency of 45 Hz per m/s (13.7 Hz per ft/s) nominal.
- The output signal is provided directly via electric cable. Supplied cable is standard 8 m (26.4 ft) long, with a maximum length of 300 m (990 ft) for Hall sensor and 16 m (52.8 ft) for Coil sensor.
- The standard sensor can be installed in pipe sizes from DN80 to DN600 (3" to 24"). Special versions on request for other sizes.
- The sensor provides a 2" GAS (BSP) male thread for connection to the pipe. All kinds of Hot-Tap clamp saddles or clamp saddles with isolation valve, with 2" GAS (BSP) female connection, are suitable for the installation.
- The nominal measuring range is from 0.15 to 8 m/s (0.5 to 25 ft/s).

Connections to FlowX3 Instruments

Flow X3 Sensors	Flow X3 Instruments				
	F9.00	F9.01	F9.02	F9.20	F9.50
F111.H	■	■	■		■
F111.C				■	

Dimensions F111 Sensor

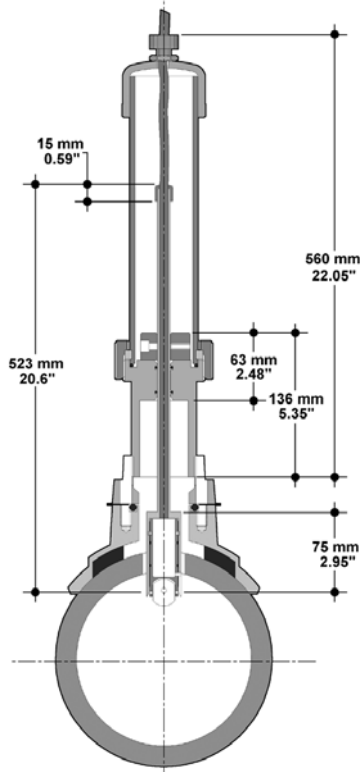

Standard Pipe Range:

- DN80 to DN600 (3" to 24").
- Special order for other sizes.

Installation Fittings

The sensor provides a 2" GAS (BSP) male thread for connection to the pipe. All kinds of Hot-Tap clamp saddles or clamp saddles with isolation valve, with 2" GAS (BSP) female connection, are suitable for the installation.

Please refer to Installation Fittings section for more details and the complete list of items available in our range.

Installation Guidelines

- Different pipe configurations and obstacles in the flow line such as valves, elbows, pipe bends and strainers create variations on the flow profile.
- The six most common installation configurations are shown to help in selecting the best location in the pipeline for paddlewheel flow sensor.
- For more information, please refer to EN ISO 5167-1.
- Always maximize distance between flow sensors and pumps.

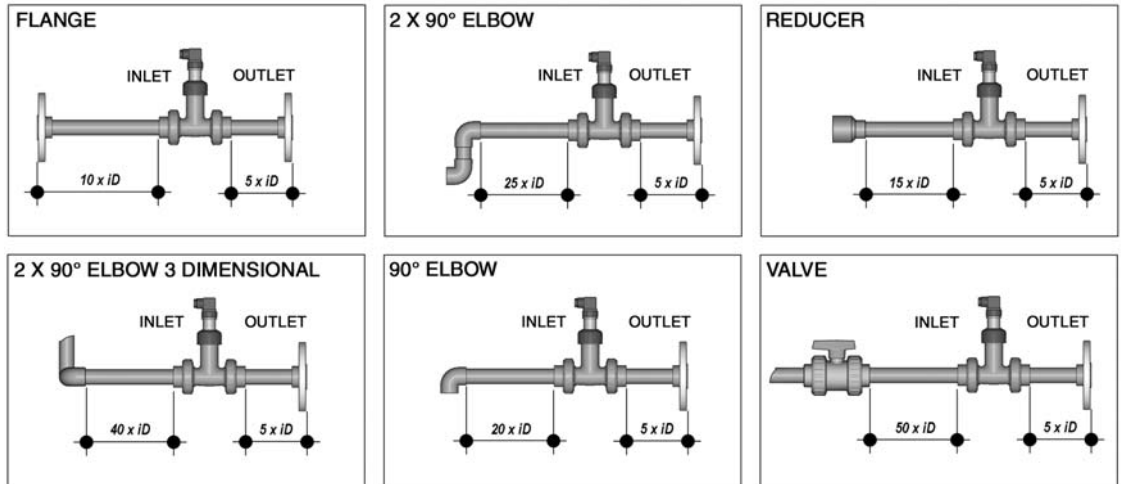

Mounting Positions

Make sure the pipeline is always full.

- Horizontal pipe runs:
 - Fig. 1: installation with no sediments present
 - Fig. 2: installation with no air bubbles present
 - Fig. 3: installation if sediments or air bubbles may be present.

- Vertical pipe runs:
 - Install sensor in any orientation.
 - Upward flow is preferred to ensure full pipe.

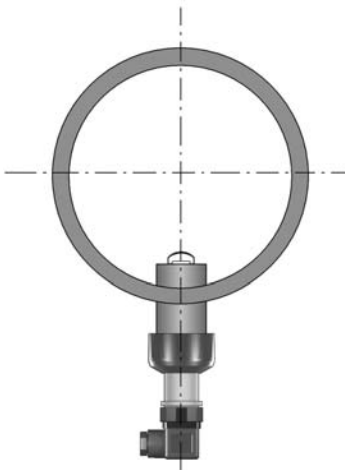

Fig. 1

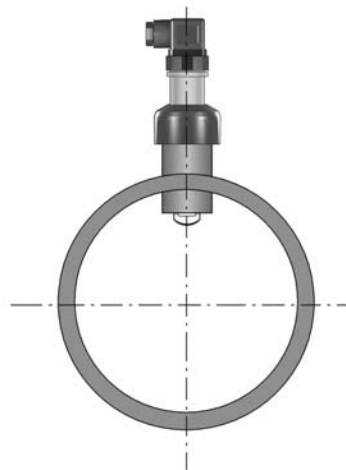

Fig. 2

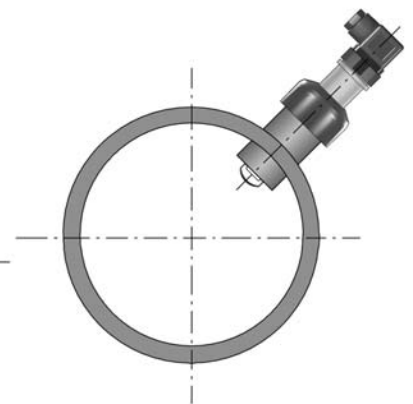
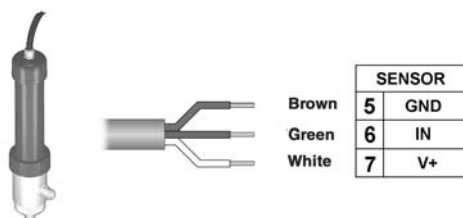

Fig. 3

Wiring

F111.H Sensor Connection to FlowX3 Instruments



F111.H Sensor Connection to Other Brand Instruments

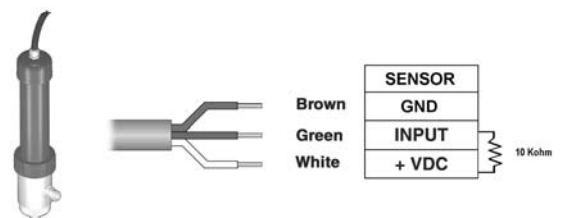

Wiring F111.C Sensor Connection to FlowX3 Instruments

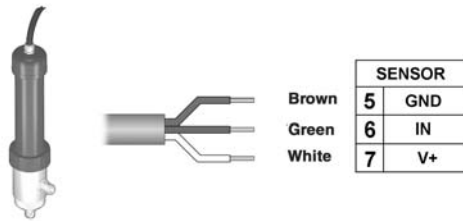

F111.C Sensor Connection to Other Brand Instruments

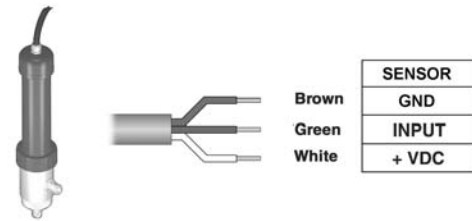

10Kohm Pull-up resistor is never required.

Technical Data

General (for both F111.H and F111.C)

- Pipe Size Range: DN80 to DN600 (3" to 24"). Special versions on request for other sizes.
- Flow Rate Range: 0.15 to 8 m/s (0.5 to 25 ft./s).
- Linearity: ± 0.75 % of full scale.
- Repeatability: ± 0.5 % of full scale.
- Minimum Reynolds Number Required: 4500.
- Enclosure: IP68.
- Maximum operating pressure/temperature: 20 bar (290 psi) @ 80°C (176°F).
- Sensor fitting joint: 2" BSP (male).
- Pressure Intake: quick connection $\frac{3}{8}$ ".
- Wetted Materials:
 - Sensor Body: AISI 304 Stainless Steel
 - Sensor joint: AISI 304 Stainless Steel
 - O-rings: EPDM
 - Rotor: ECTFE (Halar®)
 - Shaft: Ceramic (Al₂O₃)
 - Bearings: Ceramic (Al₂O₃).

Standards & Approvals

- Manufactured under ISO 9002.
- CE.

Specific for F111.H

- Supply voltage: 5 to 24 VDC regulated.
- Supply current: < 30 mA @ 24 VDC.
- Output signal: square wave.
- Output frequency: 45 Hz per m/s nominal (13.7 Hz per ft/s nominal).
- Output type: transistor NPN open collector.
- Output current: 10 mA max.
- Cable length: 8 m (26.4 ft) standard, 300 m (990 ft) maximum.

Specific for F111.C

- Supply voltage: 3 to 5 VDC regulated or 3.6 Volt Lithium battery.
- Supply current: < 10 μ A.
- Output signal: square wave.
- Output frequency: 45 Hz per m/s nominal (13.7 Hz per ft/s nominal).
- Min. input impedance: 100 K Ω .
- Cable length: 8 m (26.4 ft) standard, 16 m (52.8 ft) maximum.

Ordering Data

FlowX3 F111.X Sensor

Part No.	Version	Power supply	Description
F111.H	Hall	5 - 24 VDC	Hot-Tap Insertion Hall Flow Sensor
F111.C	Coil	3 - 5 VDC	Hot-Tap Insertion Coil Flow Sensor

Spare Parts

Part No.	Name	Description
F3.SP4	Rotor KIT	ECTFE (Halar®) rotor with Ceramic Shaft and Bearings
F1.SP1	Hall Sensor Body	Stainless Steel Hall Sensor Body
F1.SP2	Coil Sensor Body	Stainless Steel Coil Sensor Body
F1.SP3	Isolation Valve	2" Brass Ball Valve
F3.SP6	Electrical Cable	Cable (per meter), 22AWG, 3 cond.